





**BI-ENERGY**

 Petrol engine

 Single-phase Electric motor

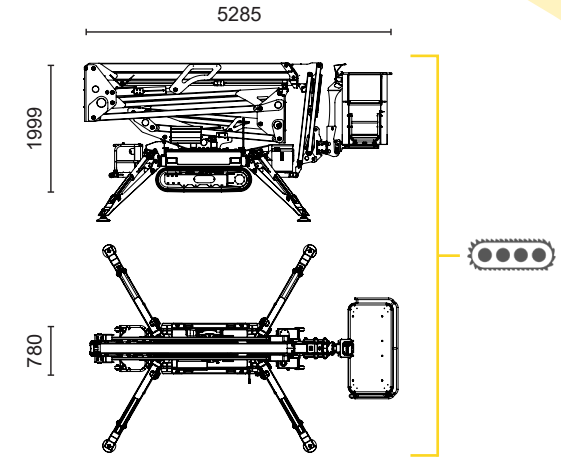
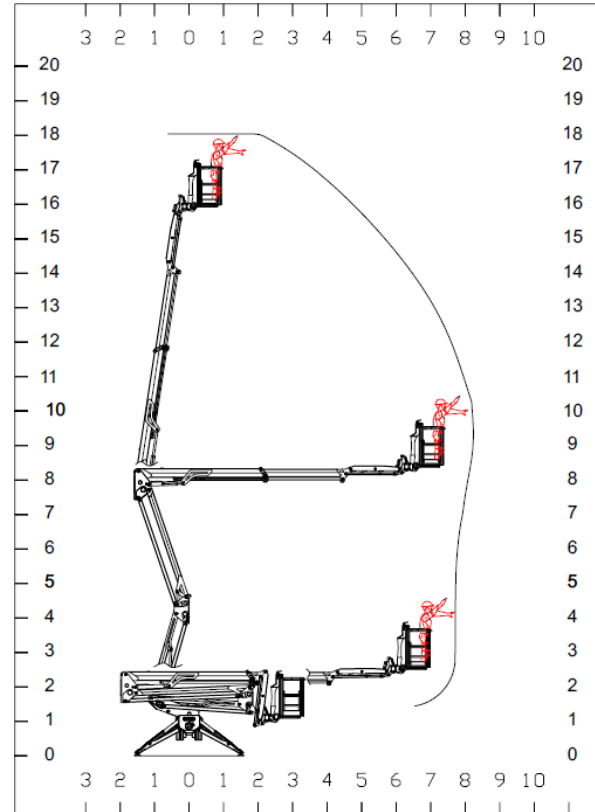

TZJ 180/C  18 m 8,2 m 230 kg +/- 180° 140x70 cm 0° / 90° 3 m 27% 26% 2 km/h 2500 kg 25 N/cm<sup>2</sup> 2,4 kN/m<sup>2</sup> 3,15 kN/m<sup>2</sup>

Available power options:

**ECO** (AC+BATTERY)

**HYBRID** (PETROL+AC+BATTERY)

The technical data may deviate +/- 3% from the specified values.

Characteristics and technical data are informative only and subjected to change without notice.

**PRELIMINARY**

Palazzani Industrie S.p.A.

Via del Pavione, 4 - 25050 - Paderno F.C. (BS) - Italy

Tel. (+39) 0306857073

info@palazzani.it

www.palazzani.it





**ECO**









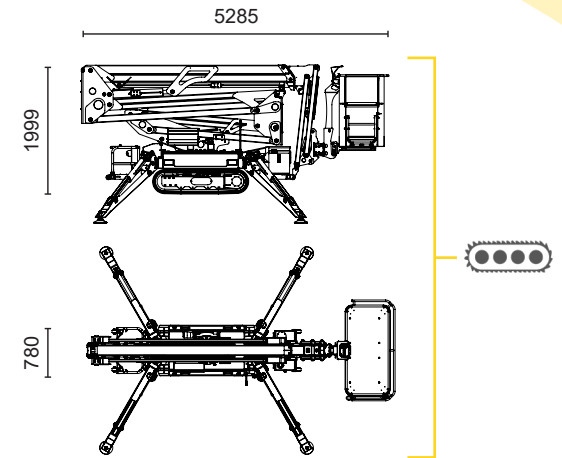
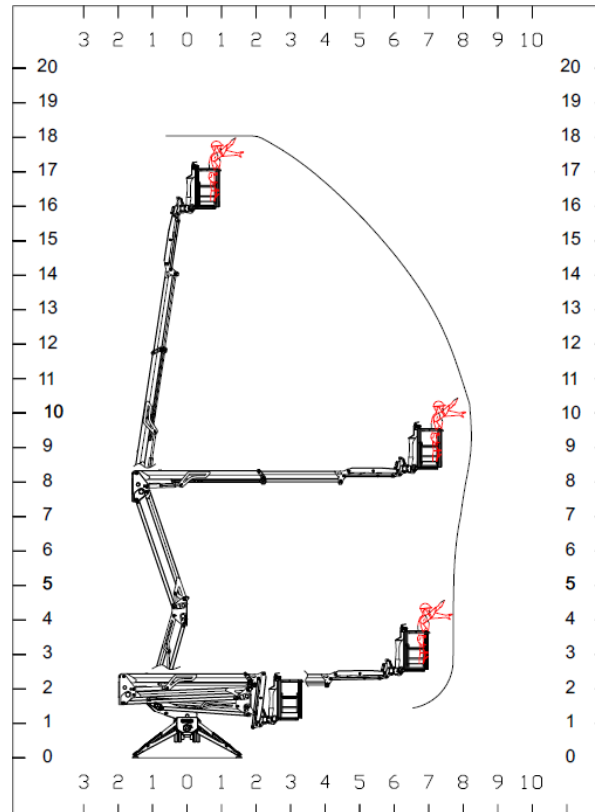







---

 Inverter actuated  
Electric motor

---

 Lithium iron  
phosphate battery  
LiFePO4



															
TZJ 180/C		18 m	8,2 m	230 kg	+/- 180°	140x70 cm	0° / 90°	3 m	27%	26%	2 km/h	2550 kg	25,5 N/cm2	2,45 kN/m2	3,21 kN/m2

Available power options:  
**BI-ENERGY** (PETROL+AC)  
**HYBRID** (PETROL+AC+BATTERY)

**PRELIMINARY**

The technical data may deviate +/- 3% from the specified values.  
 Characteristics and technical data are informative only and subjected to change without notice.

Palazzani Industrie S.p.A.  
 Via del Pavione, 4 - 25050 - Paderno F.C. (BS) - Italy  
 Tel. (+39) 0306857073  
 info@palazzani.it  
 www.palazzani.it





NC 1026 A 25





**HYBRID**

 Petrol engine

 Inverter actuated  
Electric motor

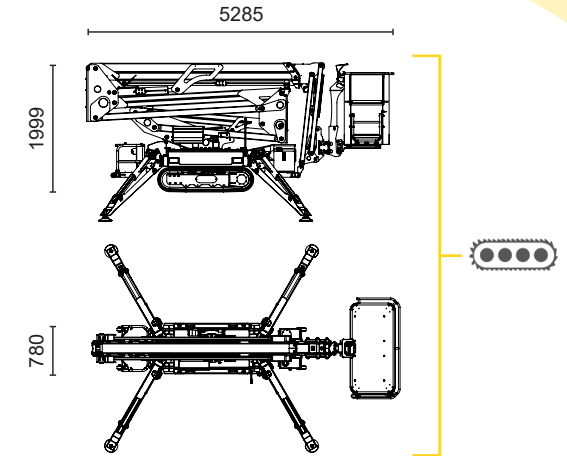
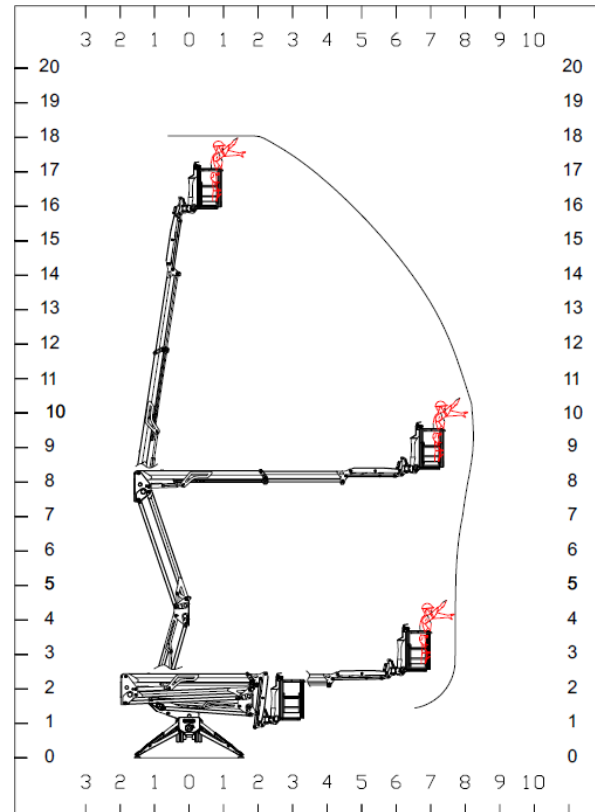
 Lithium iron  
phosphate battery  
LiFePO4



TZJ 180/C  18 m 8,2 m 230 kg +/- 180° 140x70 cm 0° / 90° 3 m 27% 26% 2 km/h 2650 kg 26,5 N/cm2 2,55 kN/m2 3,34 kN/m2

Available power options:  
**BI-ENERGY** (PETROL+AC)  
**ECO** (AC+BATTERY)

**PRELIMINARY**

The technical data may deviate +/- 3% from the specified values.  
 Characteristics and technical data are informative only and subjected to change without notice.

Palazzani Industrie S.p.A.  
 Via del Pavione, 4 - 25050 - Paderno F.C. (BS) - Italy  
 Tel. (+39) 0306857073  
 info@palazzani.it  
 www.palazzani.it

